

## SL-150 Preprogrammed Kit - How to Order

StealthLock® is ordered in kits according to the number of openings that need to be locked, the operational mode desired, the user code, and the supervisor code. These kits come completely programmed and ready for installation. Please note that each kit contains a Transmitter Pad that will only operate the Receiver Latches packaged together with it in the kit.

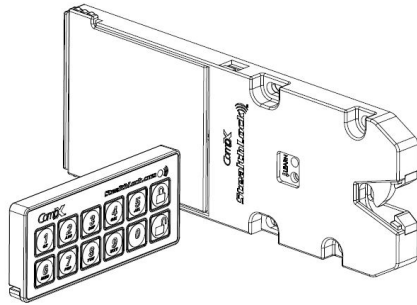

**Kit For 1 Opening**

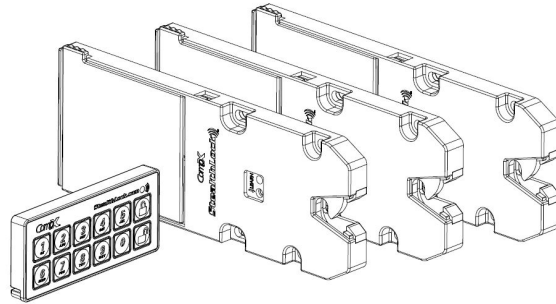

**Kit For 3 Openings**

Order StealthLock® Kits using the following part number:

**SL – 150 – NN – MM – UUUUUUUU – SSSSSSSS**

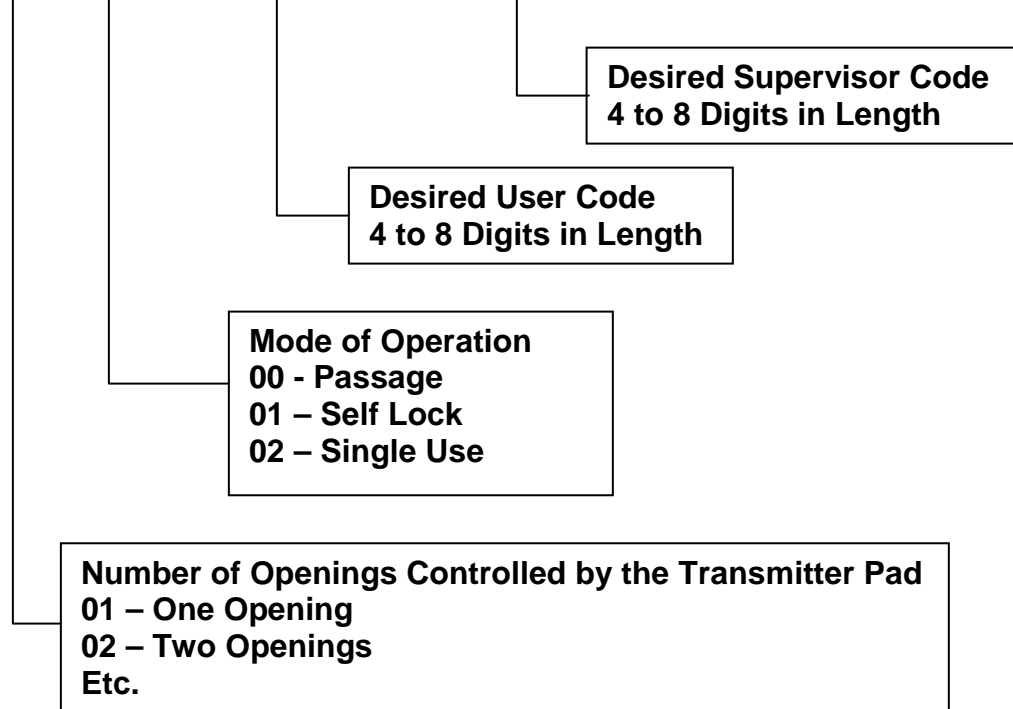

*Example:*

*SL-150-06-01-1234-555555*

*This kit would contain one Transmitter Pad and six Receiver Latches*

*The Receiver Latch would be in Self Lock mode*

*User code would be 1234 and supervisor code would be 555555*